

PERFORMANCE DATA

PAVER (TIER 4f)

BF 300 P-2



Greatest durability



Shorter set-up times



Exemplary efficiency

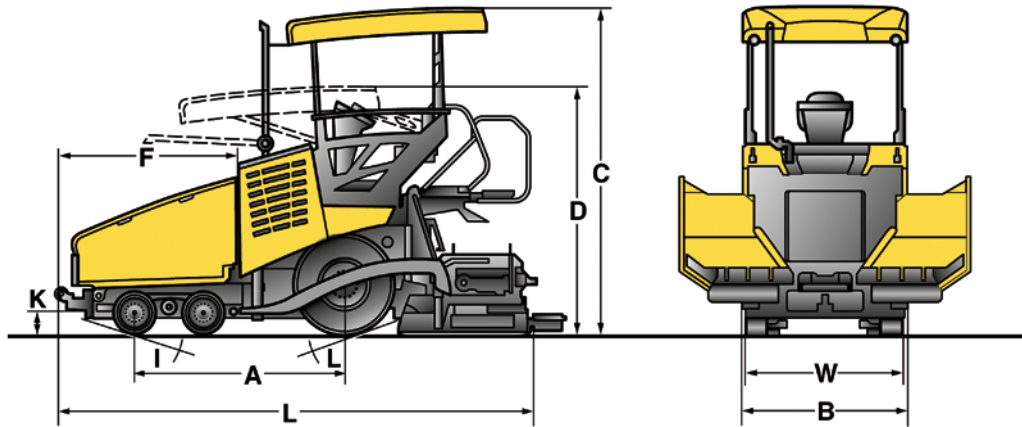

Dimensions in mm

	A	B	C	D	G	P
BF 300 P-2 S 340-2	5050	3500	500	3270	1545	720



Hydraulic front gate – for a clean material flow.



Impact-free docking – dampened bumper.



Save up to 17 % fuel – demand-driven hydraulics – with BOMAG ECOMODE.



Heats up nearly 60 % quicker – unique MAGMALIFE heating system.

Technische Daten

BOMAG BF 300 P-2

Weight CECE

With S340-2 V screed / S340-2 TV screed kg 8780 / 9000

Dimensions

Transport length mm 5050
Transport width mm 1880
Transport height mm 3270
Inner turning radius mm 2900
Outer turning radius mm 4700

Travel characteristics

Travel speed km/h 0-15
Working speed m/min⁻¹ 0-129 variable

Drive

Engine manufacturer Kubota
Type V3307-CR-T-EU
Emission stage Stage III b / Tier 4f
Cooling liquid
Number of cylinders / Displacement cm³ 4 / 3331
Rated power kW / HP 54,6 / 75

Undercarriage

Rear tyres / Number 2
Type 13 R 22.5
Front tyres / Number 2
Diameter mm 470
Width mm 280

Hopper

Capacity m³ 4,8
Width (wings open) mm 3080
Width (wings closed) mm 2270
Length mm 1800
Filling height (middle) mm 515

Conveyor

Number 2
Rotary speed U/min 33
Individual control Standard
Reversing operation yes

Auger

Number mm 2
Auger diameter mm 280
Rotary speed U/min 87
Reversing operation Standard

Screed

Basic width retracted mm 1700
Basic width extended mm 3400
Min. width with reduction skids mm 700
Mat thickness mm 250
Screed plate depth mm 330
Screed plate thickness mm 12
Heating electric
Crown % -2,5 ... +4,5
Tmaper frequency Hz 0-29
Vibration frequency Hz 20-58
Basic weight kg 1500 / 1720
Max. working width mm 4400

Filling capacities

Fuel l 95
Hydraulic oil l 80

Standard Equipment

Operator compartment

- SIDEVIEW
- Driver's seat: with swivel and side-shift
- Dashboard protection
- Hydraulic hinged roof
- Digital display for machine Management

Tractor

- ECOMODE
- Separate control of hopper wings
- Hydraulic, height adjustable auger
- Track scraper
- 2 proportionally controlled and reversible wear-resistant cast augers; screw blades separately replaceable
- 2 independent and reversible scraper belts; high-wear resistant plates
- 2 x 6 wheel drive

Screed

- L.C.S. Screed relief and traction increase system
- Screed temperature control
- MAGMALIFE Aluminium heating plates
- MAGMALIFE Automatic screed heating
- Mechanical screed lock
- Crown adjustment
- Side control of auger/scraper belts

Other

- Tools
- 8 work lights
- Three phase Generator
- Socket 240 volt

Optional Equipment

Operator compartment

- Weather protection for platform
- Seat warmer
- Asphalt steam extraction

Tractor

- Central lubrication system
- Optional paint finish
- Biologically degradable hydraulic oil
- 4 x 6 all-wheel drive
- Hydraulic hopper front flap
- Spring dampened push rollers
- Cleaning kit

Screed

- Hydraulic crown adjustment
- Heated side plates
- L.C.S. half-sided
- S 340-2 extensions:
 - 350 mm
 - 500 mm
- Reduction shoes

Levelling systems

- Height and cross-slope sensing by means of ultrasonic or mechanical sensors

Other

- Fleetmanagement BOMAG TELEMATIC
- Moon-light balloon
- LED working lights

